

Mod.: FCV10G

Rev. 00 / Tav. 01

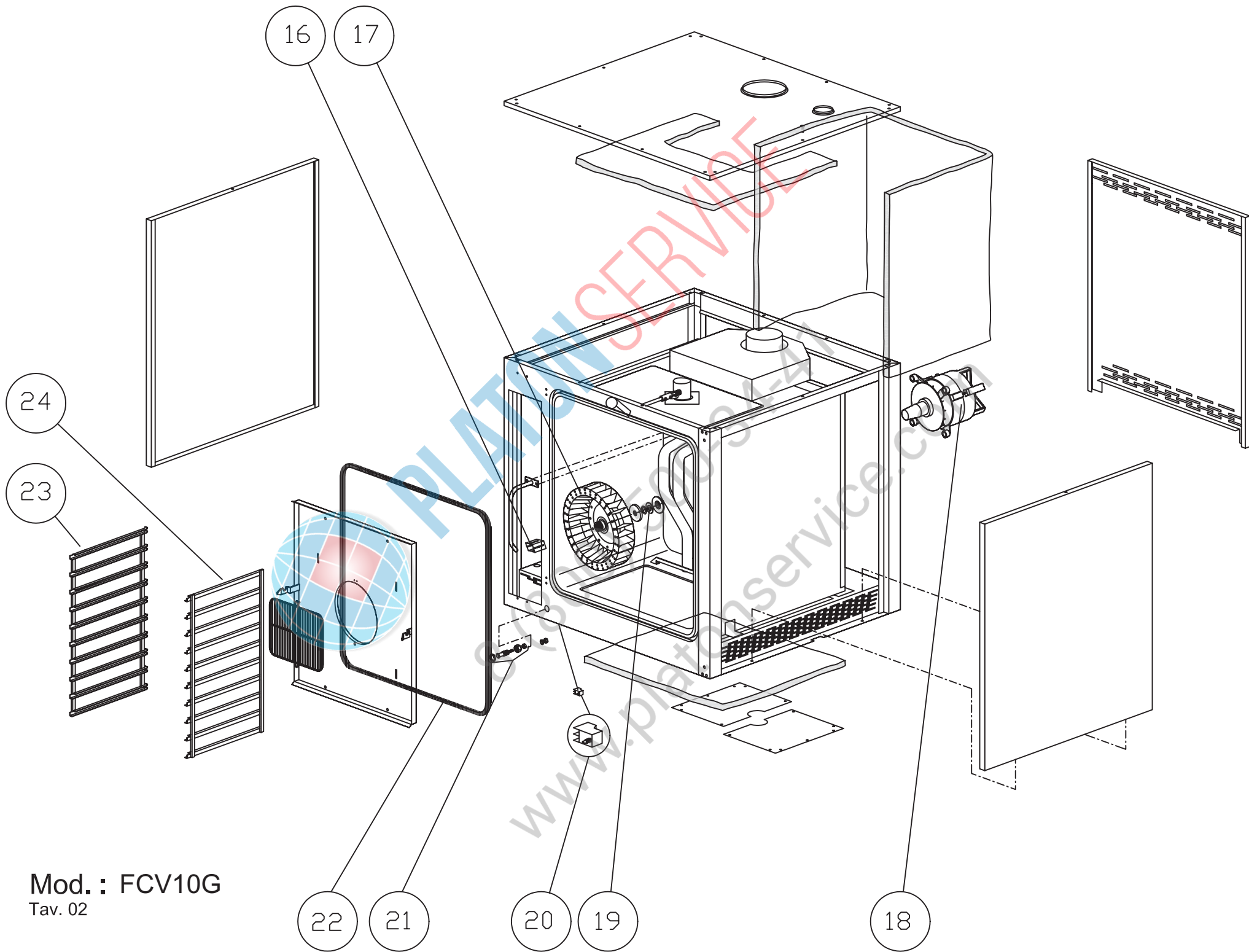

Mod. : FCV10G
Tav. 02

29

28

27

26

25

30

31

32

Mod.: FCV10G
Tav. 03

37

36

35

34

33

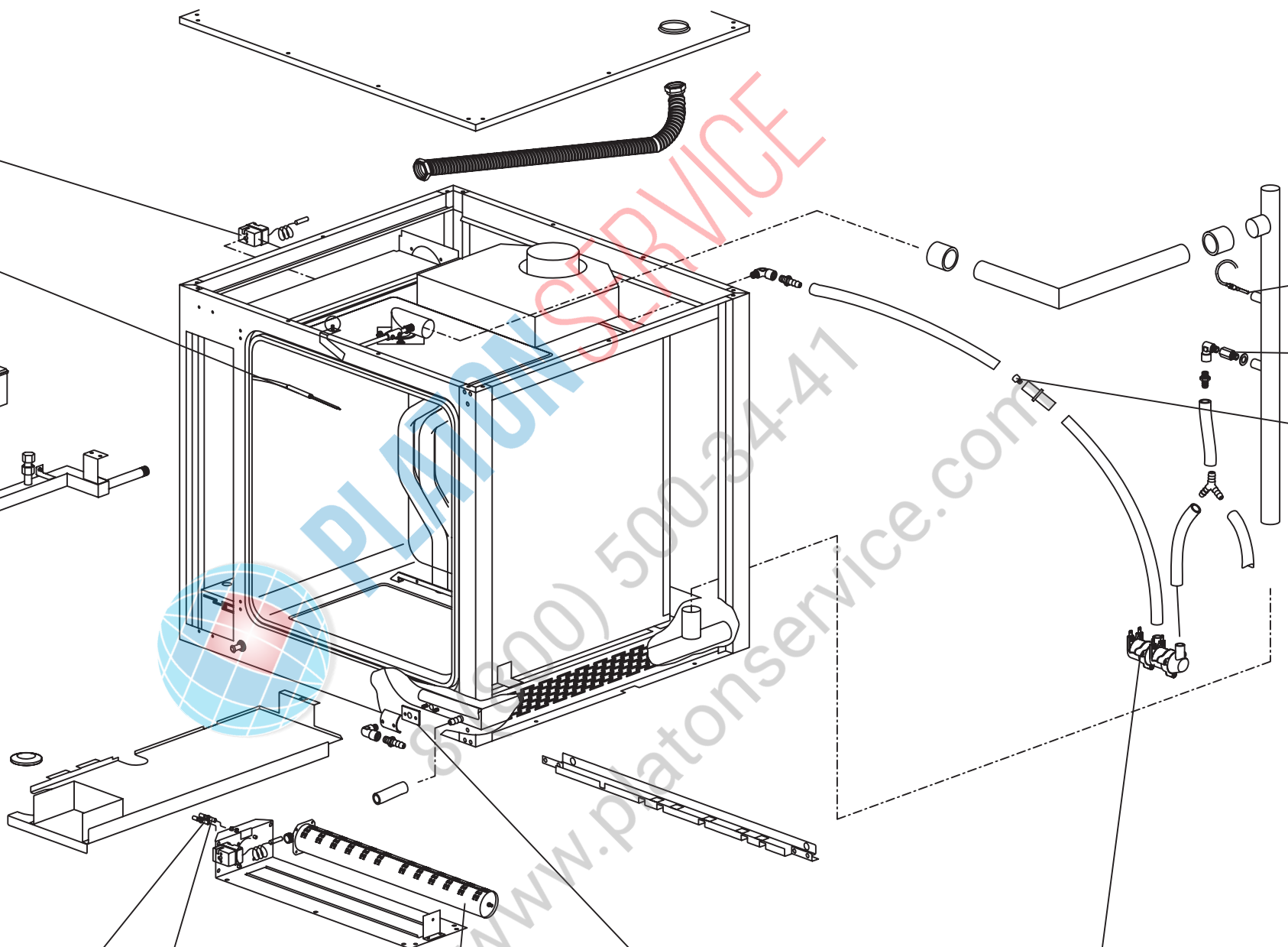

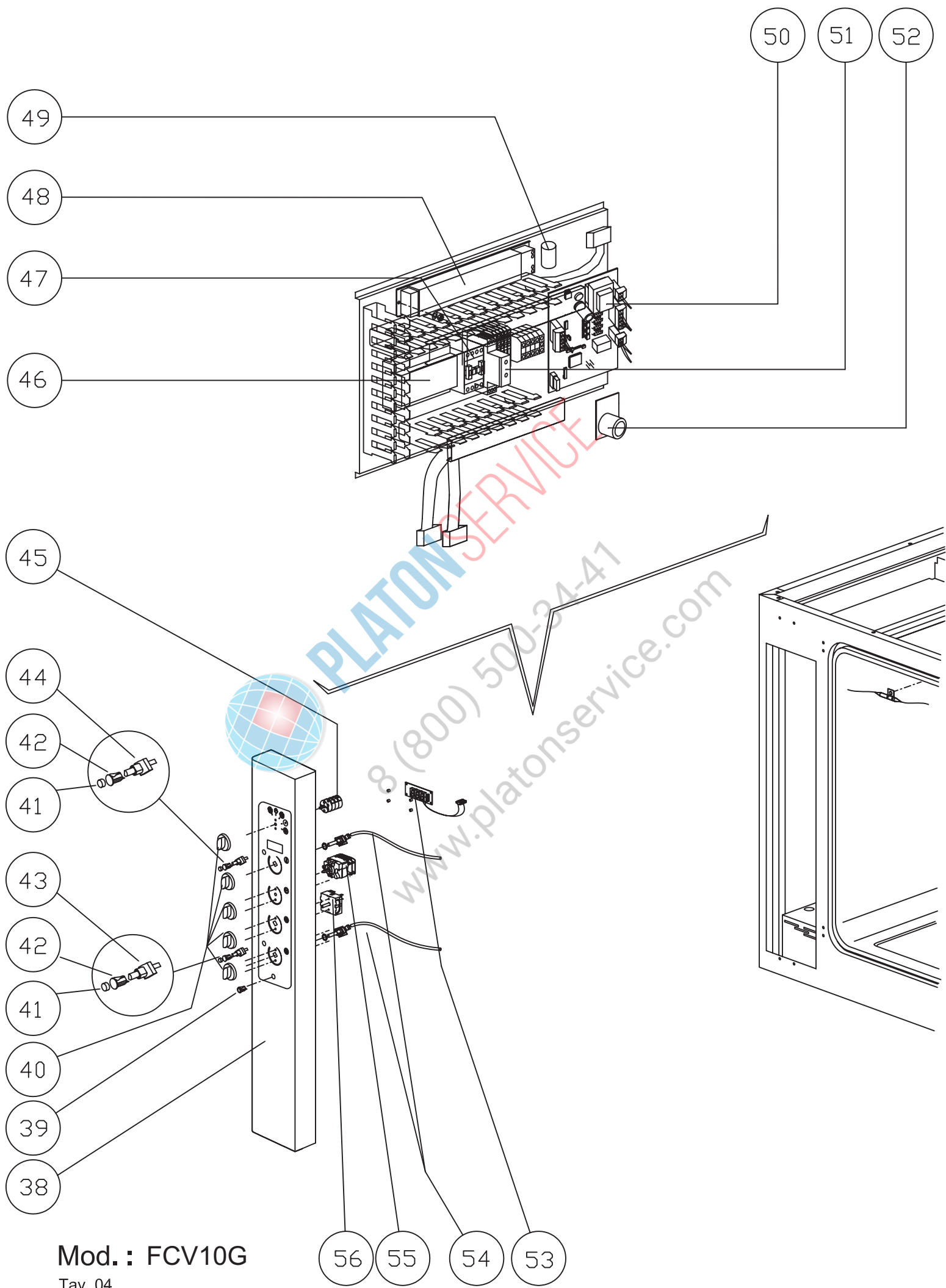

Mod. : FCV10G

Tav. 04

POS.	ITA	GB	F	D	E	CODICE
1	Maniglia per porta forno completa	Oven door knob (complete)	Poignée pour porte four complète	Griff für ofentür komplett	Asa para puerta horno completa	2013218
2	Bussola interna maniglia d=36	Internal handle bushing d=36	Douille interne poignée d=36	Buchse innen griff d=36	Forro interno asa d=36	2011212
3	Guarnizione 15364/p nera x vetro	Seal 15364/p black - for glass	Joint 15364/p noir x vitre	Dichtung 15364/p schwarz x scheinbe	Junta 15364/p negra x cristal	7070179
4	Perno sup. Per porta d.19	Suppoer spindle for door d.19	Pivot sup. Pour porte d.19	Stift ober für tür d.19	Perno sup. Para puerta d.19	2011881
5	Porta completa	Door (complete)	Porte complète	Komplette tür	Puerta completa	2013101
6	Portalamada cablato completo	Wired lamp-holder (complete)	Douille câblée complète	Verkabelte lampenfassung komplett	Portalámparas cableado completo	2012516
7	Lampada alogena 12v 20w	Halogen bulb 12v 20w	Lampe halogène 12v 20w	Halogenlampe 12v 20w	Luz alógena 12v 20w	6061054
8	Nasello x chiusura 01.0218	Whiting for closing	Mentonnet de fermeture	Verschluss	Codillo para cierre	5900122
9	Perno regolazione porta d.20	Adjustment spindle for door d.20	Pivot réglage porte d.20	Einstellstift tür d.20	Perno regulación puerta d.20	2011882
10	Bacinella s/condensa forno ass.ta	Condensation drain tray (oven) (assembly)	Bac s/condensation four assemblé	Zus gebauter schale l/kondenswasser ofen	Cubeta v/agua condens. Horno ens.da	2011892
11	Vetro serigrafato x forno ass.to	Silf-screened glass panel for oven (assembly)	Vitre sérigraphiée x chambre assemblée	Zus gebauter serigraphiertes glas für ofen	Cristal serigrafiado para horno ens.do	2013113
12	Bacinella r/condensa vetro ass.ta	Condensation collector tray (glass) (assembly)	Bac r/condensation vitre assemblé	Zus gebauter schale r/kondenswasser glas	Cubeta r/agua condens. Cristal ens.da	2011888
13	Portalamada completo lamp.vet.ca.	Lamp-holder (complete) for glass lamp ca.	Douille complète lamp. Vitre ch.	Lampenfassung komplett	Portalámparas completo lamp.vet.ca.	6063075
13A	Vetro x lampada	Glass for lamp	Vitre por lampe	Lampenglas	Cristal para lámparas	6063077
14	Riscontro x perno micro porta	Counterplate for door microswitch spindle	Butée x pivot microcontact porte	Anschlag x stift türmikroschalter	Alojamiento para perno micro puerta	2011887
15	Vetro temp. per forno	Glass for oven	Vitre pour four	Gehärtetes glass	Cristal templado para horno	5900807
16	Iniettore	Injector	pulvérisateur	Injektornabe	Inyector	2011806
17	Ventola forno pala polig. 310x100	Oven fan with polygonal blades 310x100	Ventilateur four pale polyg. 180x100	Gebläse ofen polig. Flügel 310x100	Ventilador horno pala polig. 310x100	5901010
18	Motore as.3ph/1ph 3046 hp1,0	Motor as.3ph/1ph 3046 hp1,0	Moteur as.3ph/1ph 3046 hp1,0	Motor as.3ph/1ph 3046 hp1,0	Motor as.3ph/1ph 3046 hp1,0	6032150
19	Guarnizione albero m. 9461-15x33x3	Shaft seal m. 9461-15x33x3	Joint arbre m. 9461-15x33x3	Dichtung welle m. 9461-15x33x3	Junta eje m. 9461-15x33x3	7070151
20	Micro bip. a pulsante VBR0004	Two-pole microswitch to push button VBR0004	Microcontact bip. a bouton VBR0004	Mikroschalter zweipolig mit drückknopf VBR0004	Micro bip. a pulsador VBR0004	6043088
21	Perno micro porta ass.to	Door microswitch spindle (assembly)	Pivot microcontact porte assemblé	Zus gebauter stift türmikroschalter	Perno micro puerta ens.do	2011886
22	Guarnizione 08716 nera x porta	Seal 08716 black - for door	Joint 08716 noir x porte	Dichtung 08716 schwarz x tür	Junta 08716 negra x puerta	7070166
23	Paratia sinistra	Left partition	Cloison gauche	Linker Feuerschott	Mamparo izquierdo	2014597
24	Paratia destra	Right partition	Cloison droite	Rechter Feuerschott	Mamparo derecho	2014596
25	Controllo di fiamma efd 0503xxx	Flame control efd 0503xxx	Contrôle de flamme efd 0503xxx	Flammenkontrolle efd 0503xxx	Control de llama efd 0503xxx	7020085
26	Corpo valvola sit tandem 0830041	Valve body sit tandem 0830041	Corps vanne sit tandem 0830041	Ventilkörper sit tandem 0830041	Cuerpo válvula sit tandem 0830041	7020080
27	Filtro antisturbo flcs270501	Suppressor flcs270501	Filtre antiparasites flcs270501	Entstörfilter flcs270501	Filtro antiparásito flcs270501	6090057
28	Sonda PT100 tubo 110x4 cavo 1400	Sensor pt100 tube 110x4 cable 1400	Sonde pt100 tube 110x4 câble 1400	Sonde pt100 schlauch 110x4 kabel 1400	Sonda pt100 tubo 110x4 cavo 1400	6000083
29	Termostato 3f sic.350°C 5532562807	Thermostat 3f safety.350°C 5532562807	Thermostat 3f séc.350°C 5532562807	Thermostat 3f sic.350°C 5532562807	Termostato 3f seg.350°C 5532562807	6010008
30	Sonda ntc cavo 1,5ml d.6x30	Ntc sensor with 1,5ml wire d.6x30	Sonde ntc câble 1,5ml d.6x30	Ntc-sonde kabel 1,5ml d.6x30	Sonda ntc cavo 1,5ml d.6x30	6000100
31	Ugello per abbattimento vapore	Steam reduction nozzle	Buse abattement vapeur	Düse zur dampfbeseitigung	Tobera para abatimiento del vapor	2006624
32	Ugello x umidificatore d. 0,6 m7x1	Umidifier nozzle d. 0,6 m7x1	Buse x humidificateur d. 0,6 m7x1	Düse für befeuchter d. 0,6m7x1	Boquilla x humidificador d. 0,6 m7x1	2011784
33	Elettrovalvola 1 via c/filtro v240	1-way solenoid valve with filter v240	Électrovanne 1 voie + filtre v240	1-wegiges magnetventil mit filter v240	Electroválvula 1 via c/filtro v240	6042070
34	Guarnizione x flangia s.u. .58x46	Flange seal s.u. .58x46	Joint x bride s.u. .58x46	Dichtung x flansch s.u. .58x46	Junta para brida s.u. 58x46	2011777
35	Brucciore polidoro 103.2598.10	Polidoro burner 103.2598.10	Brûleur polidoro 103.2598.10	Brenner polidoro 103.2598.10	Quemador polidoro 103.2598.10	7090101
36	Candela rilevazione fiamma	Flame detection spark plug	Bougie détection flamme	Flammenerkennungskerze	Bujía medición llama	2012110
37	Candela accensione	Ignition spark plug	Bougie allumage	Zündkerze	Bujía encendido vap.	2012111
38	Cruscotto compl.forno gk E-STEAM	Oven control panel (complete) gk E-STEAM	Bandeau de commande compl.four gk E-STEAM	Kompl. Bedienblende ofen gk E-STEAM	Tablero compl.horno gk E-STEAM	2014691
39	Pulsante lum. 1x3a p12n31600000	Illuminated button 1x3a p12n31600000	Bouton-poussoir lum. 1x3a p12n31600000	Leuchtknopf 1x3a p12n31600000	Tecla lum. 1x3a p12n31600000	6032038
40	Manopola serigrafata per forno d=6	Silk-screened knob for oven d=6	Bouton sérigraphié pour four d=6	Serigraph. Griff für ofen d=6	Llave serigrafiada para horno d=6	2012261
41	Tasto D16 bianco 111258	Button D16 white 111258	bouton-poussoir D16 111258	Knopf D16 111258	Tecla D16 bianco 111258	6031032
42	Supporto per tasti D16 nero 111297	Black surround D16 111297	Contre-cadre noir D16 111297	Schwarzer gegenrahmen D16 111297	Contramarco negro D16 111297	6031033
43	Pulsante unip. CME2009	Single-pole button CME2009	Bouton-poussoir unip. CME2009	Einpoliger weisser CME2009	Tecla unip. CME2009	6031031
44	Interruttore unip. CME1012	Single-pole Switch CME1012	Interrupteur unip. CME1012	Einpoliger Schalter CME1012	Interruptor unip. CME1012	6031030
45	Commutatore 7x16a 5p cs0169138291	Commutator 7x16a 5p cs0169138291	Commutateur 7x16a 5p cs0169138291	Umschalter 17x16a 5p cs0169138291	Commutador 7x16a 5p cs0169138291	6030030
46	Scheda controllo inversione marcia	Control/direction reversal board	Carte contrôle inversion marche	Steuerplatine umsteuerung	Circuito control inversión sentido	6010084
47	Contattore trip. 25a/ac1 b.230v 1l	Three-pole contactor 25a/ac1 b.230v 1l	Contacteur trip. 25a/ac1 b.230v 1l	Dreif. Schaltschütz 25a/ac1 b.230v 1l	Contacto trip. 25a/ac1 b.230v 1l	6046038
48	Trasformatore str105si-h 11,5/230v	Transformer str105si-h 11,5/230v	Transformateur str105si-h 11,5/230v	Transformator str105si-h 11,5/230v	Transformador str105si-h 11,5/230v	6041065
49	Filtro antisturbo 411.13.2210	Suppressor 411.13.2210	Filtre antiparasites 411.13.2210	Entstörfilter 411.13.2210	Filtro antiparásito 411.13.2210	6090050
50	Scheda termoregolatore base	Thermoregulation board	Carte thermorégulateur	Platine wärmerегler	Circuito termorregulador	6010096
51	Temporizzatore pausa lav L45PL240	Timer washing pause L45PL240	Temporisateur L45PL240	Zeitgeber L45PL240	Temporizador L45PL240	6042056
52	Scheda buzzer con cavo	Buzzer board with cable	Carte avertisseur avec câble	Platine buzzer mit kabel	Circuito buzzer con cable	6010103
53	Scheda termoregolatore display	Display thermoregulation board	Carte thermorégulateur afficheur	Platine wärmerегler display	Circuito termorregulador display	6010095
54	Potenzimetro con cavo	Potentiometer with cable	Potentiomètre avec câble	Potentiometer mit kabel	Potenciómetro con cable	6010097
55	Temporizzatore 120'logarit. M8 65	Timer 120'logarithmic m8 65	Temporisateur 120'logarit. M8 65	Zeitgeber 120'logarit. M8 65	Temporizador 120'logarit. M8 65	6032047
56	Regolatore ener.45er104c1 16a 220v	Energy regulator 45er104c1 16a 220v	Régulateur éner.45er104c1 16a 220v	Regler ener.45er104c1 16a 220v	Regulador ener.45er104c1 16a 220v	6031023